



4000 Series

PORTABLE



DeMARCO INDUSTRIAL VACUUMS

The **Portable DeMARCO Vacuum 4000 Series** is precisely engineered and manufactured to the highest standards, therefore providing you with a level of unsurpassed quality, value and performance.

The 4000 Series is ideal for ultra heavy-duty wet/dry material applications that may require up to a 14" ID hose size with pick up capacities up to 48 tons/hour. This design includes a 4-point powerhead air-lift package requiring no manual hand-lift or fork-lift truck for hopper sealing. The Portable 4000 Series may also be connected to a central manifold system with multiple pick up point connections.

YOUR SEARCH STOPS HERE™

DeMARCO Vacuums are purposely built for decades of heavy-duty use with our exclusive performance features that are virtually maintenance-free. From our heavy gauge steel fabrications, to our time tested quality components and expert machine craftsmen, we are confident to stand behind every vacuum system that carries the DeMARCO name worldwide by offering our exclusive **Limited LIFETIME Warranty - Nothing Less.**

INDUSTRIES SERVED

<u>FOUNDRY</u>	<u>FOOD</u>	<u>MILLS</u>	<u>MINING</u>	<u>PLASTIC</u>	<u>POWER PLANT</u>	<u>MISC.</u>
ALUMINUM	FLOUR	CHEMICALS	ASPHALT	FLAKES	COAL	COATING
BRONZE	GRAIN	SAWDUST	BRICK	POWDER	FLY ASH	GLASS
CARBON BLACK	SALT	PAPER	CEMENT	PELLETS	SLURRY	SODA ASH
METAL	SUGAR	PULP	CONCRETE	RESINS		POWDERS
ORES		WOOD CHIPS	GRAVEL			ETC.
SAND CLAYS			LIMESTONE			
STEEL SHOT			MINERALS			

PERFORMANCE

Model	HP	Vacuum (”Hg) Rating*	CFM	Inlet ID Hose Size	Tons/ Hour**
4400	40	16”	950	4”	10
4500	50	16”	1150	5”	14
4750	75	16”	1620	6”	20
4100	100	16”	2110	8”	30
4125	125	16”	2810	10”	36
4150	150	16”	3410	12-14”	48

Above performances are approximate ratings under STP.

* Vacuum capabilities up to 27” Hg available on select models.

** Actual values may differ based upon distance from blower and material characteristics such as bulk density, particle size and operator's efficiency.

DeMARCO MAXCARTRIDGE™ FILTERS

4000 Series

- Exclusive Long Lasting Custom Design
- Washable and Reusable
- High Burst Strength with Dimensional Stability
- Dimpled, Non-Clogging Open Pleat Design
- Handles Ultra-Fine Powders
- Abrasion and Chemical Resistant
- Efficiencies up to 99.99% @ 0.2 Microns & Above
- Interval Air-Pulse Cleaning for Uninterrupted Vacuuming. No Manual Filter Shaking Required
- Secondary In-line or HEPA Filters Available
- Various Filter Medias Available
- Filter Performance Guarantee

* Minimum 80 PSI Compressed Air Required for Filter Pulse Cleaning During Vacuuming.



DIMENSIONS

Roll Hopper in Cubic Yards	L	W	H
1-1/2	8'-2"	5'-6"	9'-7"
2	8'-5"	6'-7"	9'-4"
2-1/2	8'-4"	6'-7"	10'-5"

Custom dimensions available.
HEPA Filter Option may add to overall height.

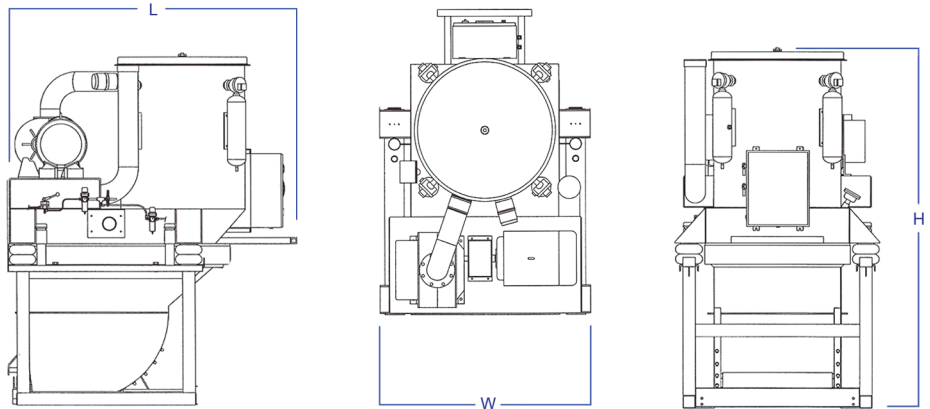

FEATURES & BENEFITS

Patented Features

- DeMARCO Material Offset Separation Circuit Provides Minimal Carryover to the Filtration Chamber Maximizing Filter Performance.
- Exclusive Line of Cyclone Separators
- DeMARCO Silencer Base® Muffler
 - Low dBA Rating
 - Compact and Esthetic Design
 - Solid Support Structure for the Drive Package
 - Fork Tine Openings for Vacuum Mobility

Control Panel

- NEMA 4 or 4X Enclosures
- 480V/3PH/60HZ or as Required
- Start/Stop Push-Buttons
- Material High Level Detector with Auto Shutdown
- Differential Pressure Switch for Filter Protection
- Magnehelic and Vacuum Gauges
- Vacuum Pump High Temperature Protection Circuit
- Engineered Electrical Drawings Included
- UL Approved
- **Options:**
 - NEMA 7/9 X-Proof Packages
 - 12V DC Panel
 - PLC Touch Screen Terminal

Drive Package

- High Performance Positive Displacement Vacuum Pumps
- Continuous 24/7 Operation
- Up to 27" Hg (Mercury) Available
- High Energy Efficient Electric Motors
- V-Belt or Direct Drive
- Gas, Diesel and LPG Options

Roll Hopper and Structural Stand

- 1-1/2, 2 or 2-1/2 Material Collection Roll Dump Hoppers with Safety Latch and Skid Mounting Base
- Heavy-Duty Structural Support Stand.
- 4-Point Powerhead Air-Lift Package. Hand-Lift or Fork-Lift Truck Required for Hopper Sealing
- Optional Over-the-Road Trailer Mounted or In-Plant 2-Wheel/4-Wheel Tow Packages Available

Custom Engineered Vacuums

Our full service custom engineering department is dedicated to provide customer focused solutions for your toughest applications.

DeMarco Industrial Vacuum Corp
PO Box 1138
Crystal Lake, IL 60039 USA

P: 815.344.2222
F: 815.344.2223
DeMarcoVacuums.com
Sales@DeMarcoVacuums.com

